

# BAWTRY WK 34

## REBALLAST 3A/B X-Over

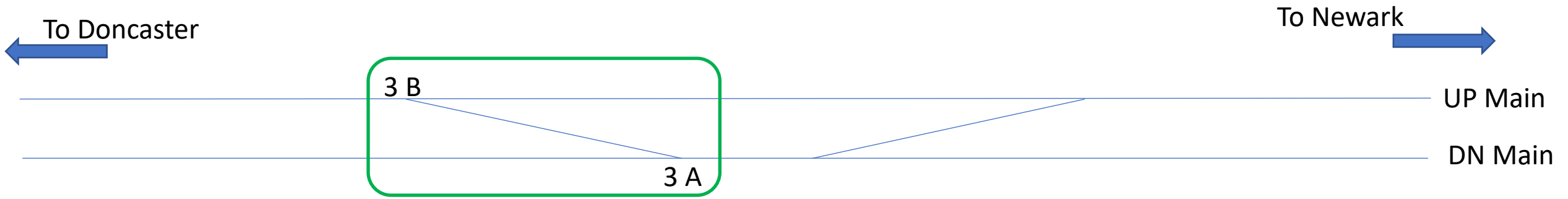



# BAWTRY WK 34

REBALLAST 3A/B X-Over

SET UP SITE AND POSITION TRAINS

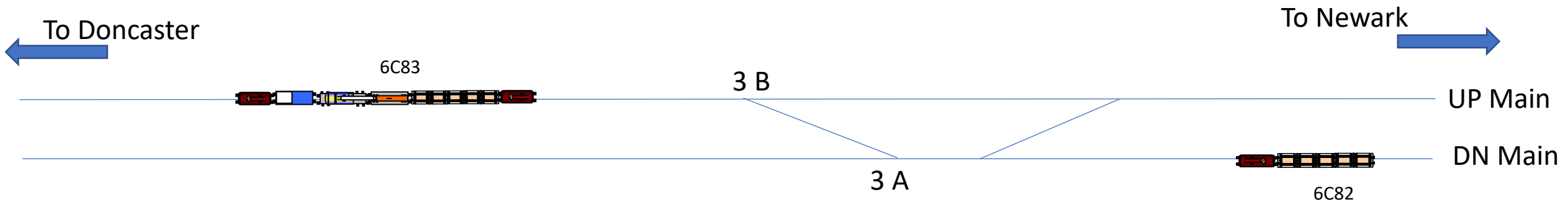

- PRT trains
- Train 1 (6C82) @ D183 Sig on the Down Main. (Loco, 11 MT Falcon, 11LD Falcon, 2 LD Salmon, Loco)
- Train 2 (6C83) @ D184 Sig on the Up Main. (Loco, 5 MT Swordfish, 5 MT Falcon, 10 LD Falcon, Kirow(810) + Support, Loco)

# BAWTRY WK 34

REBALLAST 3A/B X-Over

SET UP SITE AND POSITION TRAINS

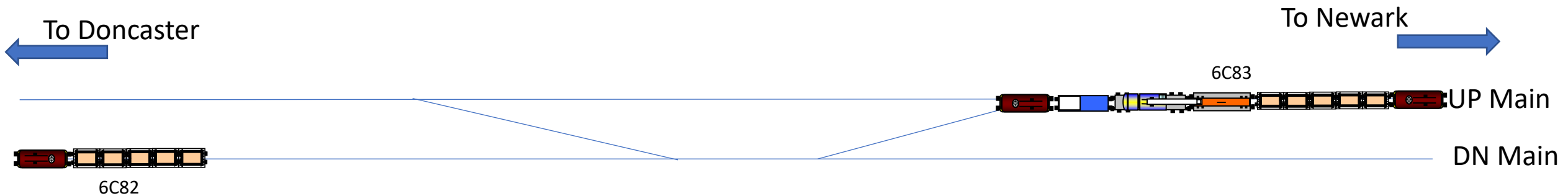

- Position trains:
- 6C82 to the low mileage of crossover on the DOWN line.
- 6C83 to travel to the low mileage side of X-over on the UP line.

# BAWTRY WK 35

REBALLAST 2A/B X-Over

SET UP KIROW

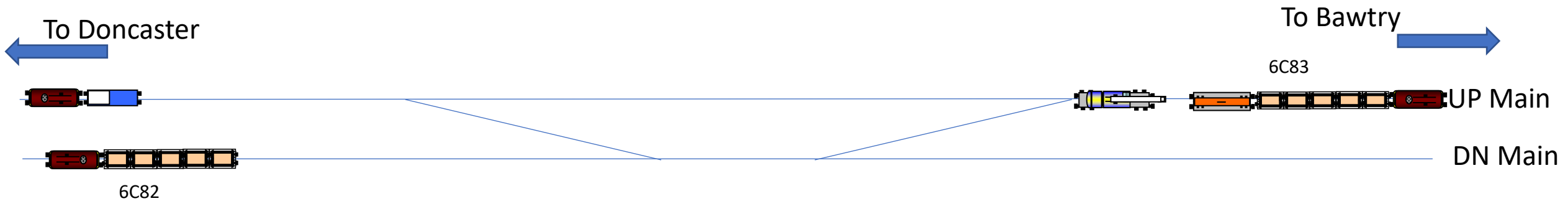

- Kirow to attach beam and detach from 6C83.
- Trailing loco and Falcon wagons to travel to high mileage of crossing
- Kirow to set up

# BAWTRY WK 34

REBALLAST 3A/B X-Over

ACCESS PEM(s) and position on site

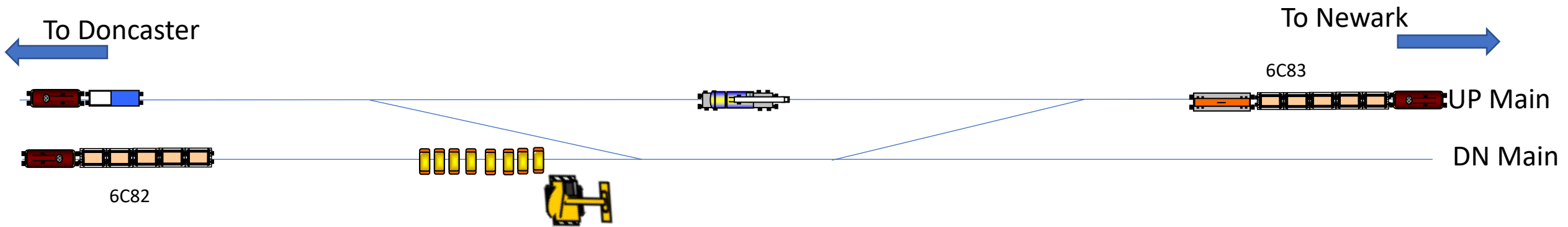

Task Name	Duration	Start	Finish
Position PEMS (Kirow to lift onto adjacent line)	2 hrs	Sat 20/11/21 06:00	Sat 20/11/21 08:00

- RRV to place PEM(s) on track

# BAWTRY WK 34

REBALLAST 3A/B X-Over

PANEL REMOVAL

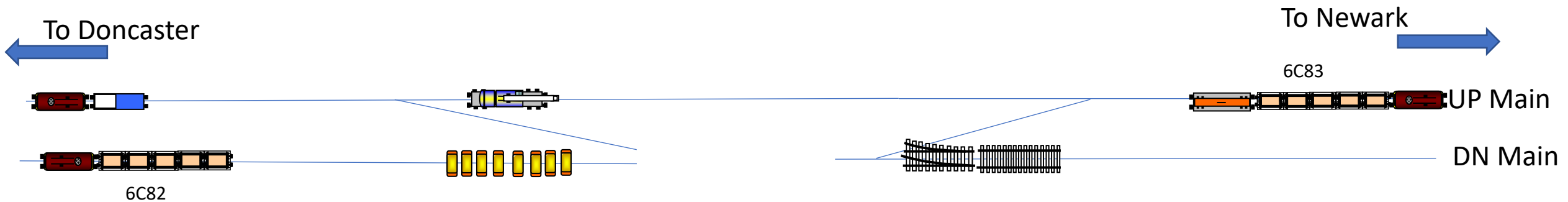

Task Name	Duration	Start	Finish
Burn and remove 1 x PL panel with Kirow and 1 x Switch and guts panel on 3A (Panels 1 -3)	1.5 hrs	Sat 20/11/21 05:30	Sat 20/11/21 07:00

- Burn and remove 1 x PL on the Down Main (Panel 1)
- Burn and remove switch from 3A (Panel 2)
- Cut and remove guts panel from 3A (Panel 3)

# BAWTRY WK 34

REBALLAST 3A/B X-Over

PANEL REMOVAL

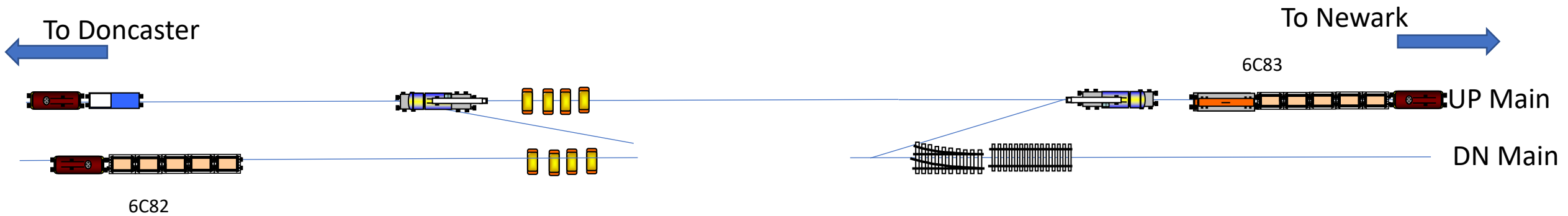

Task Name	Duration	Start	Finish
Position PEMS (Kirow to lift onto adjacent line)	2 hrs	Sat 20/11/21 06:00	Sat 20/11/21 08:00

- Kirow to lift PEMS onto the Up main for crossing panel removal



# BAWTRY WK 34

## REBALLAST 3A/B X-Over

### PANEL REMOVAL

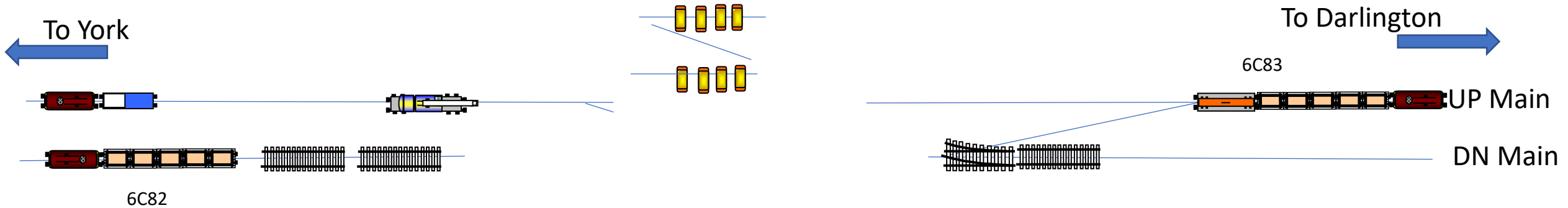

Task Name	Duration	Start	Finish
PEMS to lift crossing panel and walkout to the cess (Panel 4)	1.5 hrs	Sat 20/11/21 08:00	Sat 20/11/21 09:30
Kirow to lift out remaining 4 x PL panels on the Down main (Panels 5 - 8) and guts panel (Panel 11) from 3B	1.25 hrs	Sat 20/11/21 08:00	Sat 20/11/21 09:15

- PEMs to remove crossing panel into the Up cess (Panel 4)
- Kirow to remove 4 x plain line panels from the Down Main (Panels 5 – 8) and guts panel from 3B (Panel 11)

# BAWTRY WK 34

REBALLAST 3A/B X-Over

INSTALL TEMP PLAIN LINE PANELS ON THE UP MAIN

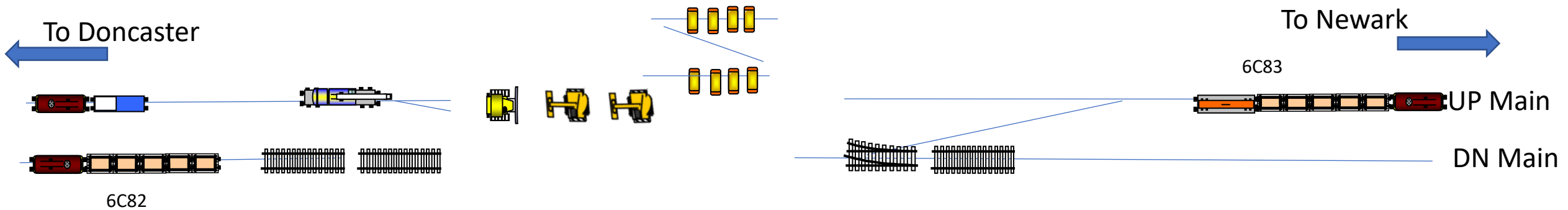

Task Name	Duration	Start	Finish
Skim dig the Up main placing spoil into the Down main	1 hr	Sat 20/11/21 09:30	Sat 20/11/21 10:30

- Access 2 x Rail bug and 1 x Dozer
- Skim dig the UP Main to allow temp panel install
- Place spoil onto the DOWN Main

# BAWTRY WK 34

## REBALLAST 3A/B X-Over

### INSTALL TEMP PLAIN LINE PANELS ON THE UP MAIN

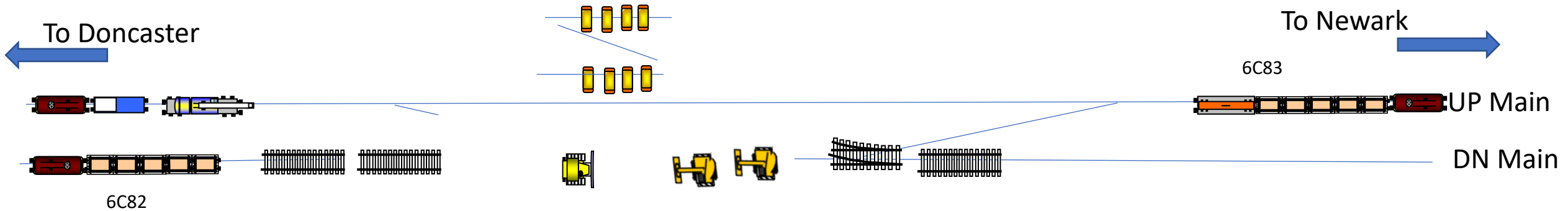

Task Name	Duration	Start	Finish
Kirow to install 3 x temporary panels to the Up Main (T1 - T3) Kirow to then spin and sit to the high mileage of renewal	1 hr	Sat 20/11/21 10:00	Sat 20/11/21 11:00

- Kirow to lift temp panels (T1, T2 & T3) from 6C82 on the Down Main
- Install the temp panels underfoot on the Up Main
- Kirow to then spin jib and sit to the high mileage of works

# BAWTRY WK 34

REBALLAST 3A/B X-Over

EXCAVATE THE DOWN MAIN

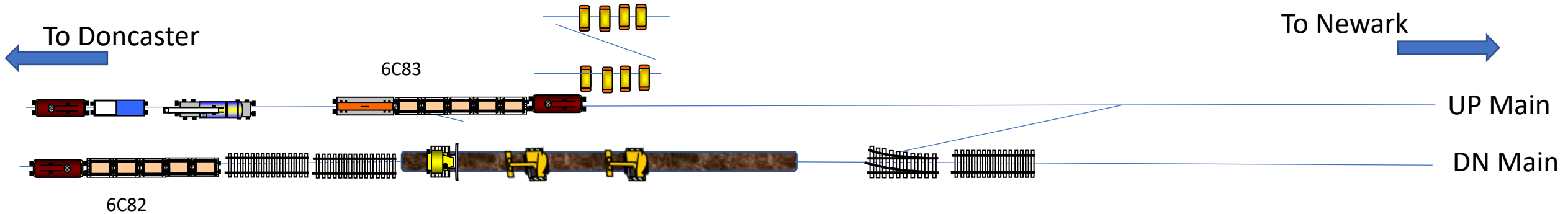

Task Name	Duration	Start	Finish
Position 6C83 on the Up Main	15 mins	Sat 20/11/21 11:00	Sat 20/11/21 11:15
Excavate and doze to design level, loading spoil to 6C83 on the Up Main	2 hrs	Sat 20/11/21 11:15	Sat 20/11/21 13:15

- Position 6C83 adjacent the site
- Excavate and doze to design levels
- Load spoil to 6C83 on the Up Main

# BAWTRY WK 34

## REBALLAST 3A/B X-Over

### INSTALL BOTTOM BALAST ON THE DOWN MAIN

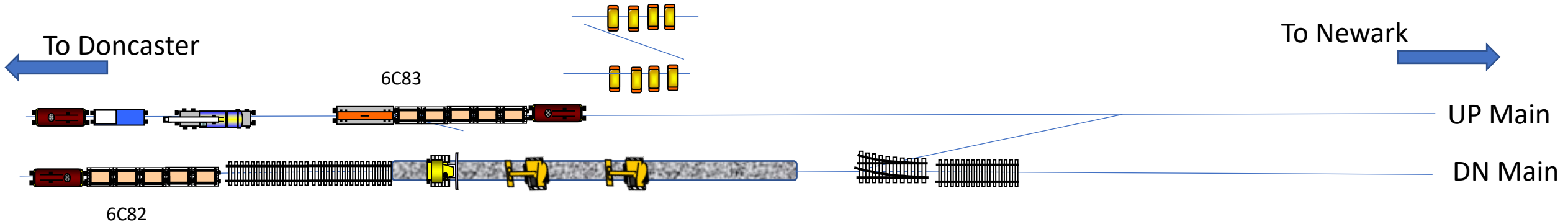

Task Name	Duration	Start	Finish
Install specified geotextile	1 hr	Sat 20/11/21 13:15	Sat 20/11/21 14:15
Offload bottom stone from 6C83 on the Up Main, and doze to design level	1.5 hrs	Sat 20/11/21 13:30	Sat 20/11/21 15:00
Consolidate bottom stone with triple whackers	1.5 hrs	Sat 20/11/21 13:45	Sat 20/11/21 15:15

- Install Geotextile
- Offload ballast from 6C83 on the Up Main and doze to design levels
- Consolidate ballast with triple whackers

# BAWTRY WK 34

## REBALLAST 3A/B X-Over

Install the Down Main and remove the UP Main

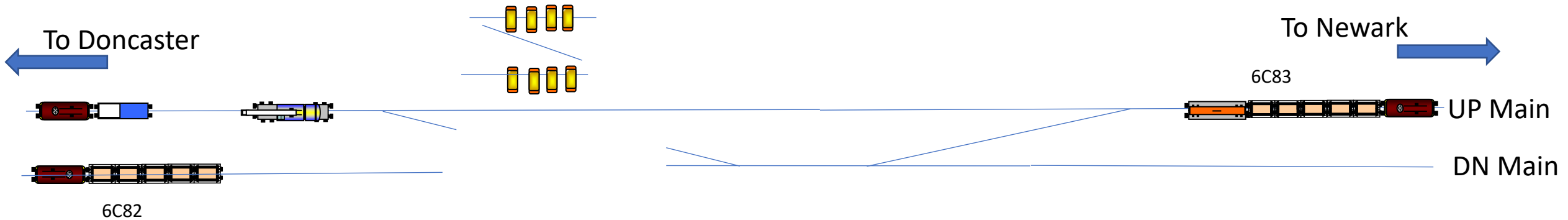

Task Name	Duration	Start	Finish
Kirow to install 1 x PL panel and switch and guts panel for 3A (Panels 1 - 3)	1.5 hrs	Sat 20/11/21 15:00	Sat 20/11/21 16:30
Kirow to install remaining 4 x PL panels (Panels 5 - 8) off the back of crossing on the Down Main	1.5 hrs	Sat 20/11/21 16:30	Sat 20/11/21 18:00

- Kirow to install toe to toe PL panel (Panel 1) on the Down Main
- Kirow to install switch and Guts panel on 3A points (Panels 2 & 3)
- Kirow to install 4 x PL panels on the Down main at high mileage end (Panels 5 – 8)

# BAWTRY WK 34

## REBALLAST 3A/B X-Over

Install the Down Main and remove the UP Main

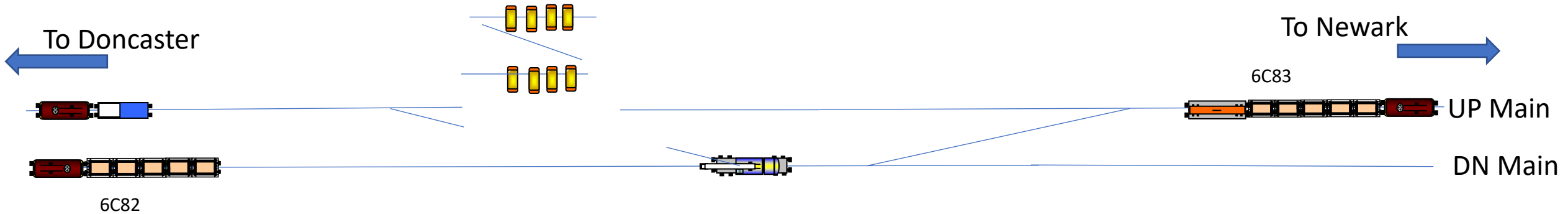

Task Name	Duration	Start	Finish
Cross Kirow to the Down main through 2A/B points	30 mins	Sat 20/11/21 18:00	Sat 20/11/21 18:30
Kirow to transfer temp PL panels (T1 - 3) from the Up to the Down Main	1 hr	Sat 20/11/21 18:30	Sat 20/11/21 19:30

- Kirow to cross to the Down main
- Kirow to transfer the temp panels (T1, T2 & T3) from the Up to Down line





# BAWTRY WK 34

## REBALLAST 3A/B X-Over

### Excavate the Up Main

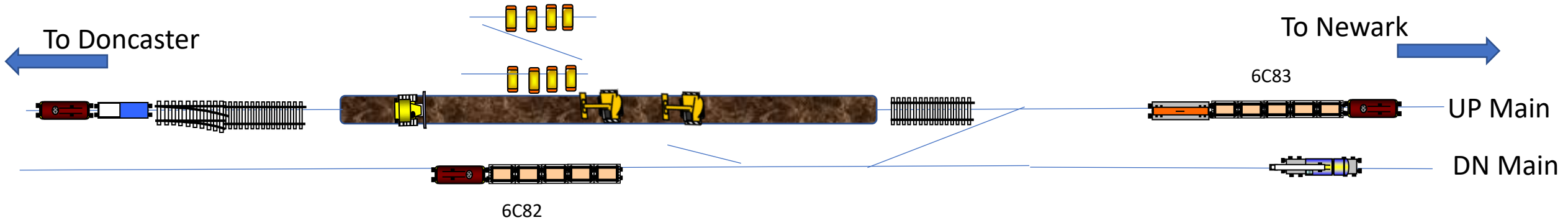

Task Name	Duration	Start	Finish
Position 6C82 on the Down Main	15 mins	Sat 20/11/21 21:20	Sat 20/11/21 21:35
Excavate and doze to design level, loading spoil to 6C82 on the Down Main	2 hrs	Sat 20/11/21 21:35	Sat 20/11/21 23:35

- Position machines for excavation of the Up Main
- Position Kirow clear of renewal and 6C82 on the Down Main
- Excavate the UP Main to design levels and load spoil to train 1

# BAWTRY WK 34

## REBALLAST 3A/B X-Over

Install bottom ballast on the Down Main

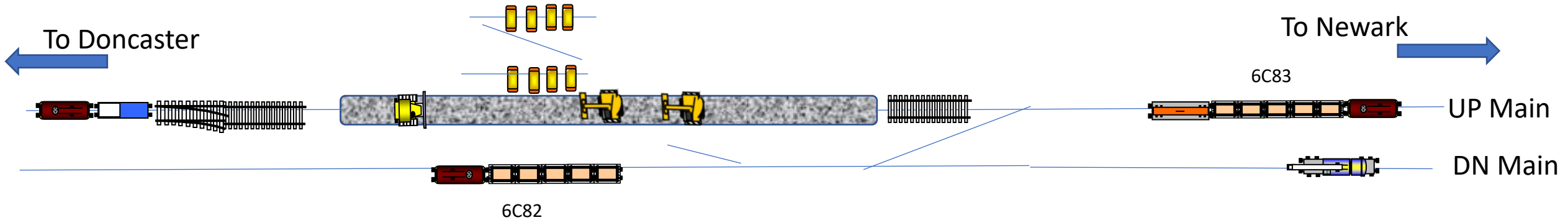

Task Name	Duration	Start	Finish
Install specified geotextile	1 hr	Sat 20/11/21 23:35	Sun 21/11/21 00:35
Offload bottom stone from 6C82 on the Down Main and doze to design level	1.5 hrs	Sat 20/11/21 23:45	Sun 21/11/21 01:15
Consolidate bottom stone with triple whackers	1.5 hrs	Sun 21/11/21 00:00	Sun 21/11/21 01:30

- Install Geotextile
- Offload ballast from 6C82
- Consolidate with triple whackers

# BAWTRY WK 34

## REBALLAST 3A/B X-Over

Remove temporary panels

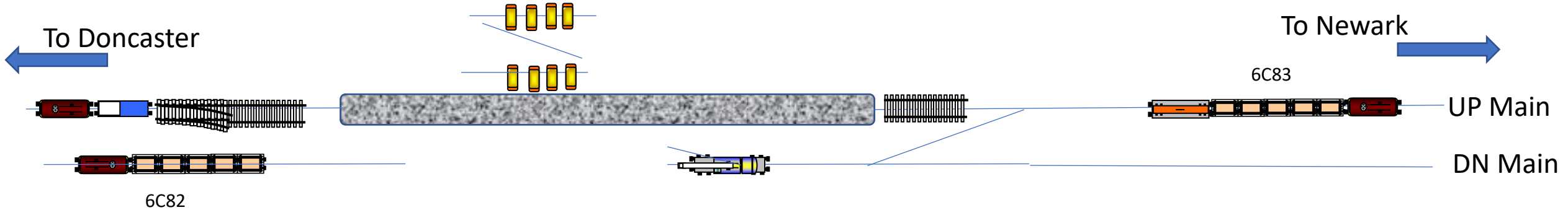

Task Name	Duration	Start	Finish
Kirow to remove temporary track panels (T 1-3) and stack in cess	1 hr	Sun 21/11/21 01:15	Sun 21/11/21 02:15

- Position train and Rail bugs off site & Egress Dozer
- Kirow to remove temp panels (T1, T2 & T3) and stack in the cess

# BAWTRY WK 34

## REBALLAST 3A/B X-Over

### Complete Installation

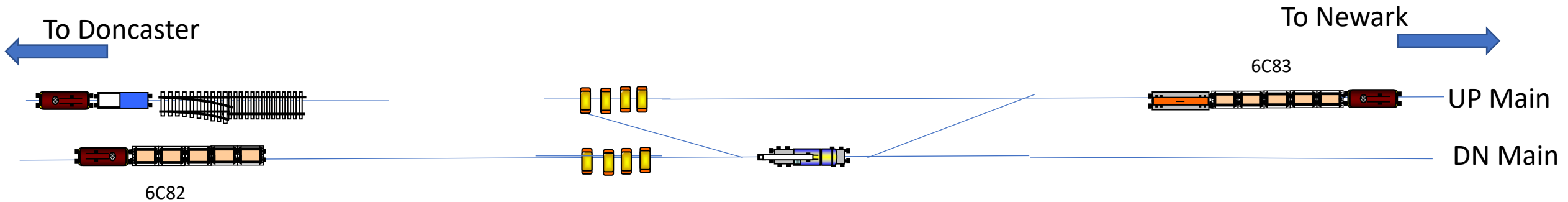

Task Name	Duration	Start	Finish
Kirow to install 2 x PL to the low mileage (Panels 9 & 10)	1 hr	Sun 21/11/21 02:15	Sun 21/11/21 03:15
PEMS to walk crossing panel (Panel 4) back into place and install new bearers	2 hrs	Sun 21/11/21 01:15	Sun 21/11/21 03:15

- Kirow to install 2 x PL panels on the UP Main (Panels 9 & 10)
- PEMs to walk crossing panel back into place (Panel 4)

# BAWTRY WK 34

## REBALLAST 3A/B X-Over

### Complete Installation

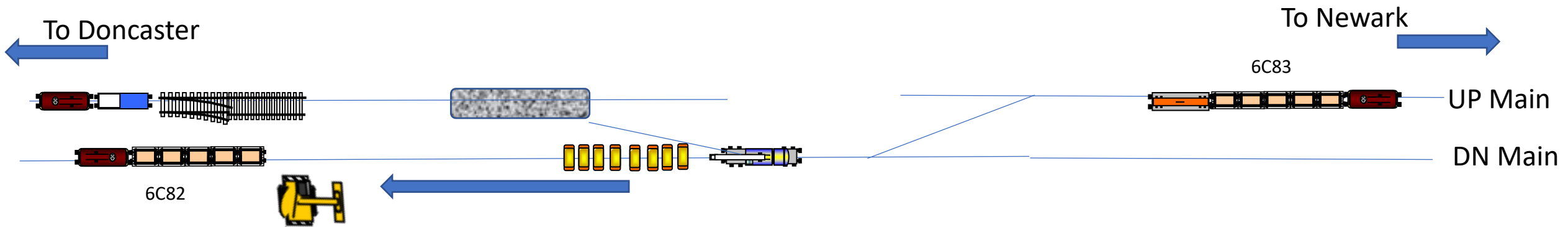

Task Name	Duration	Start	Finish
Kirow to lift PEMS from the Up to the Down line. PEMS to travel to access and RRV to remove	1 hr	Sun 21/11/21 03:15	Sun 21/11/21 04:15

- Kirow to lift the PEMS to the Down Main & RRV to remove

# BAWTRY WK 34

REBALLAST 3A/B X-Over

Complete Installation

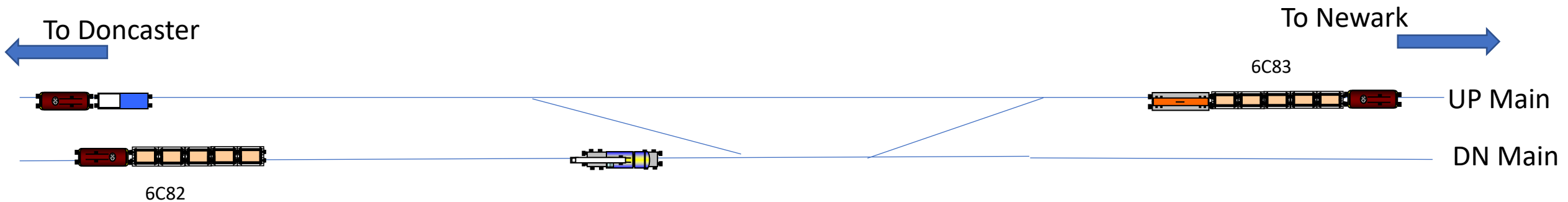

Task Name	Duration	Start	Finish
Kirow to reinstall 3B guts (Panel 11) and switch panel Panel 12 and 2 x PL panels (Panels 13 & 14) on the UP Main	2 hrs	Sun 21/11/21 04:15	Sun 21/11/21 06:15

- Kirow to install 3A Guts and Switch panels into place (Panels 11 & 12)
- Kirow to install 2 x PL panels off the front of 3A switch (Panels 13 & 14)

# BAWTRY WK 34

REBALLAST 3A/B X-Over  
Top Stone the Up Main

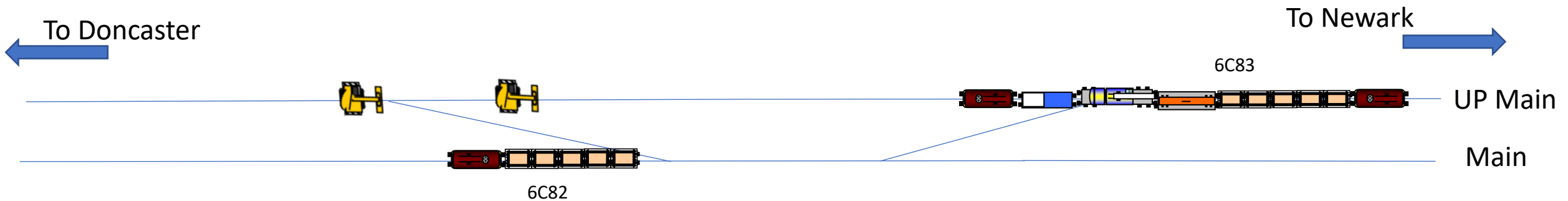

Task Name	Duration	Start	Finish
Position 6C82 on the Down Main and RRV on the Up Main	15 mins	Sun 21/11/21 10:15	Sun 21/11/21 10:30
Reform 6C83	1 hr	Sun 21/11/21 10:15	Sun 21/11/21 11:15
Offload top stone	1 hr	Sun 21/11/21 10:30	Sun 21/11/21 11:30

- 6C83 to be re-formed
- Rail bugs to offload top stone from the train 1 to the Up Main and profile
- Egress 6C82

# BAWTRY WK 34

REBALLAST 3A/B X-Over  
Top Stone the Down Main

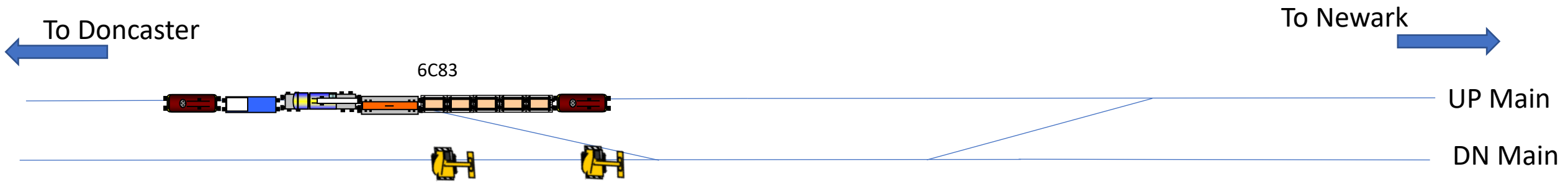

Task Name	Duration	Start	Finish
Egress 6C82, cross RRV to the Down Main and position 6C83 on the Up Main	45 mins	Sun 21/11/21 11:30	Sun 21/11/21 12:15
Offload top stone	1 hr	Sun 21/11/21 12:15	Sun 21/11/21 13:15
Egress RRV and 6C83	30 mins	Sun 21/11/21 13:15	Sun 21/11/21 13:45

- Cross Rail bugs to the Down Main and position train 2 on the Up Main
- Rail bugs to offload top stone from the train 1 to the Down Main and profile



# BAWTRY WK 34

REBALLAST 3A/B X-Over  
Egress Trains and RRVs

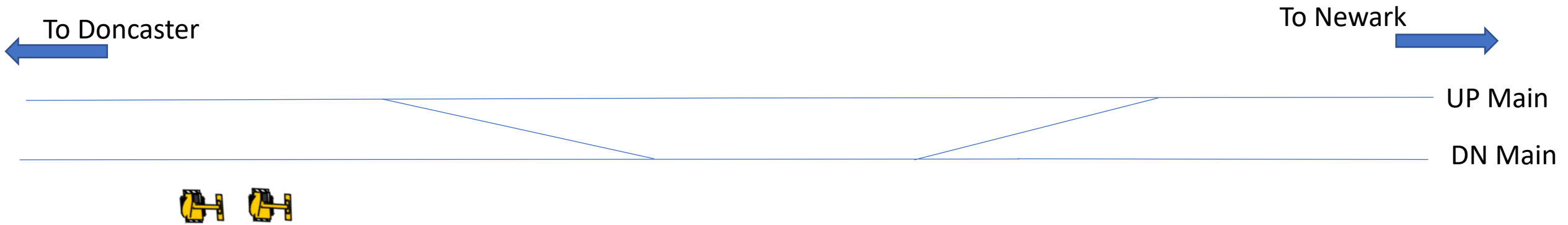

- Egress 6C83
- Off track RRV

# BAWTRY WK 34

## REBALLAST 3A/B X-Over

### Tamp

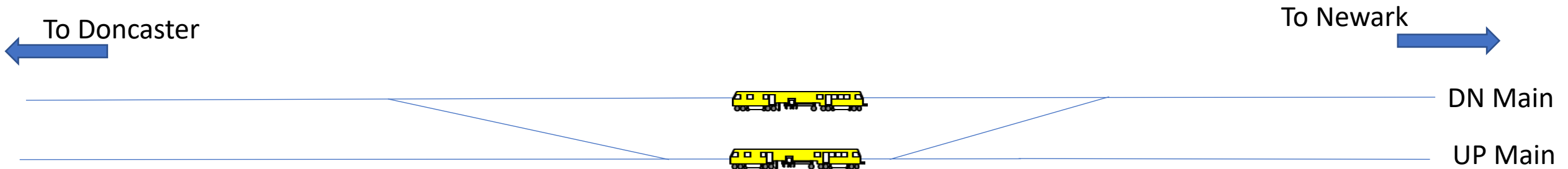

Task Name	Duration	Start	Finish
Position 2 x tampers warm up and input offset files	1 hr	Sun 21/11/21 12:45	Sun 21/11/21 13:45
Tandem tamp	3 hrs	Sun 21/11/21 13:45	Sun 21/11/21 16:45
Re-tamp as required	1 hr	Sun 21/11/21 16:45	Sun 21/11/21 17:45
Regulate ballast and clip clean	1.5 hrs	Sun 21/11/21 16:45	Sun 21/11/21 18:15

- Access 2 x tampers and position 1 on the UP and 1 on the Down
- Tandem tamp as required
- On completion egress tampers

# BAWTRY WK 34

REBALLAST 3A/B X-Over

Weld & Stress

To Doncaster



To Newark



UP Main

DN Main

Task Name	Duration	Start	Finish
Access welders and complete 28 x cold welds	6 hrs	Sun 21/11/21 17:45	Sun 21/11/21 23:45

- Access welders and complete welds

# BAWTRY WK 34

REBALLAST 3A/B X-Over

Hand back works

To Doncaster

To Newark

UP Main

DN Main

Task Name	Duration	Start	Finish
Reconnect S & T equipment	5 hrs	Sun 21/11/21 17:45	Sun 21/11/21 22:45
Wheels free testing	1 hr	Sun 21/11/21 22:45	Sun 21/11/21 23:45
Hand back isolation	1 hr	Sun 21/11/21 22:45	Sun 21/11/21 23:45
Complete final hand back checks and A-G forms	1 hr	Sun 21/11/21 22:45	Sun 21/11/21 23:45
Clear and egress site	1 hr	Sun 21/11/21 22:45	Sun 21/11/21 23:45
DWWP contingency	4 hrs	Sun 21/11/21 23:45	Mon 22/11/21 03:45
Hand back worksite	15 mins	Mon 22/11/21 03:45	Mon 22/11/21 04:00
Hand back possession	20 mins	Mon 22/11/21 04:00	Mon 22/11/21 04:20

- S & T testing
- Hand back isolation
- Complete hand back checks and give up work site